

# A FULL LINE OF INNOVATION

Keep your operations moving forward with A.G.'s high performance equipment solutions

## eTAMP™ Servo Tampers

- Automatic Backstop, Mid-bar, Tamper, Dividers, and Accumulator rack
- Adjustable at Full Production Speeds
- Order Recipe Recall System
- Increase Operator Safety

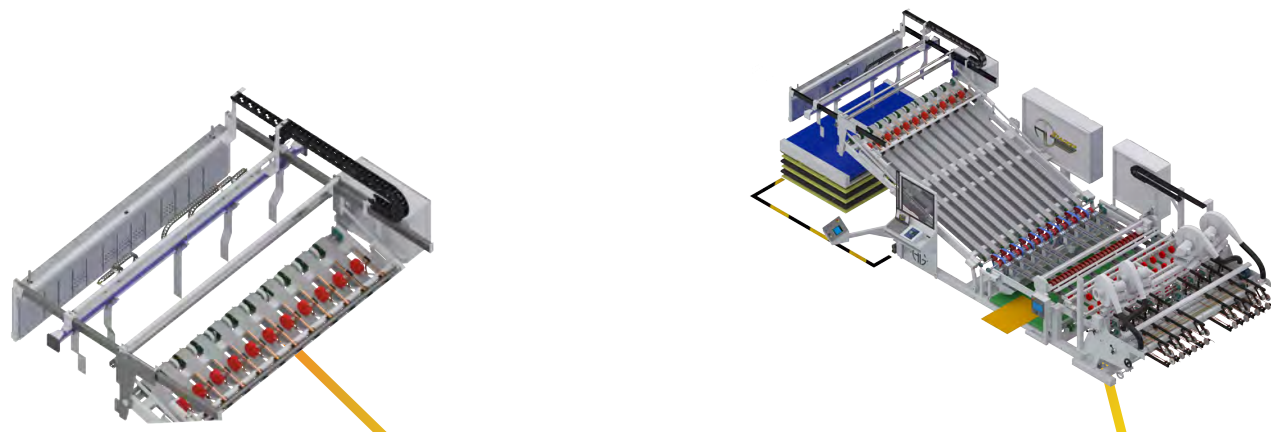

## G3™ RDC STACKER

- Speeds up to 13,500+ KPH
- Operation Control Station
- Intelligent Safety System ISS
- Accurack Accumulator Rack
- Deck Lock Out System
- Accuset Layboy Arm Adjustment
- Tampers
- Remote Diagnostic System
- Proportional Hydraulic Control
- High Performance Layboy Section
- Accumulator Back Tamping
- Flexi-Deck
- Air Operated Deck Lift
- Laxan Ventilated Reinforced Backstop
- Pivoting Hopper Guides

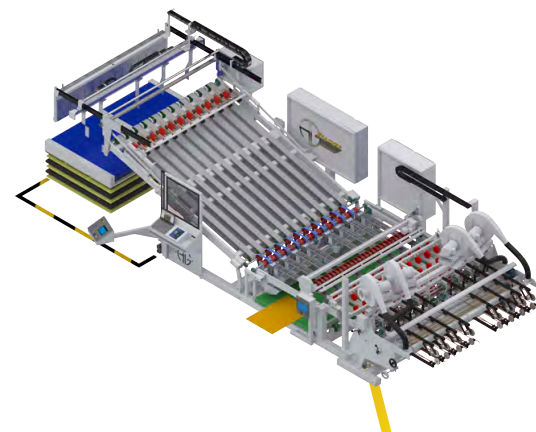

## DSS™ Divert & Separate System

- Automatic Divert & Separate
- Order Recipe Recall System
- Fast, Reliable Set Up
- Simple Swipe Touch Screen Set Up
- Recalls at the Touch of a Button
- Adjustments at the Swipe of a Finger

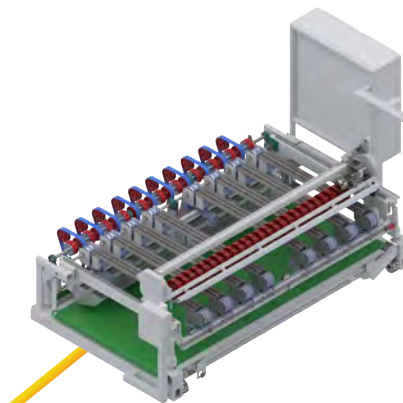

## Bundle™ Conveyor System

- No Pits
- Two Stage Conveyor System
- Discharge in Any Direction
- Ideal for Bundle Breaker Lines
- Multiple Configurations Available

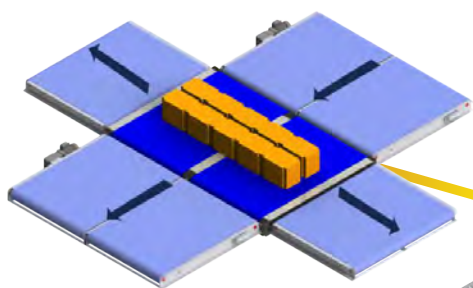

## eXT™ Stacker Front End

- Supreme Control & High Speeds - Up to 20,000 KPH
- Scrap Control System with Adjustable Nips
- Ease of Access, Roll Out Capable & Modular Design
- Order Recipe Recall System with Fast, Automated Set Up



## eBREAK™ Bundle Breaker

- Capable of Variable, Straight, Nested and Offset Breaks
- Servo-Driven Clamp & Break System
- Independent & Synchronized Platen Capability
- LIDAR 2D Technology
- Order Recipe Recall System
- Integrated Safety Features
- Fully Electric

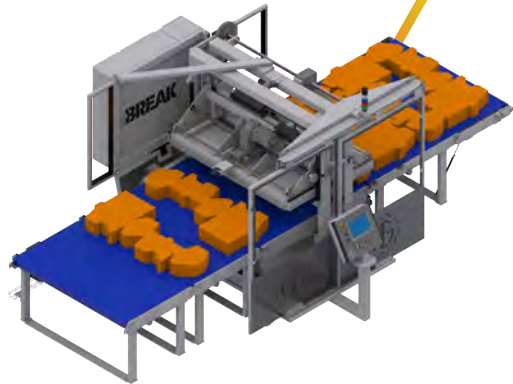

## X12™ Pitless Lift Conveyor

- Reinforced and Balanced for Heavy Loads
- No Pits Needed
- Reduce Stacker Movement
- Fully Integrated & Modular
- Dramatically Improve Discharge Cycle Time
- Integrated with ISS for Operator Safety



## SQR™ Sample Quality Rejection System

- Automatic Ejection at Specified Intervals or RDC Start
- Manual Discharge at the Push of a Button
- Ensure Personnel Safety
- Automatic Quality Control
- Discharges at Full Production Speeds

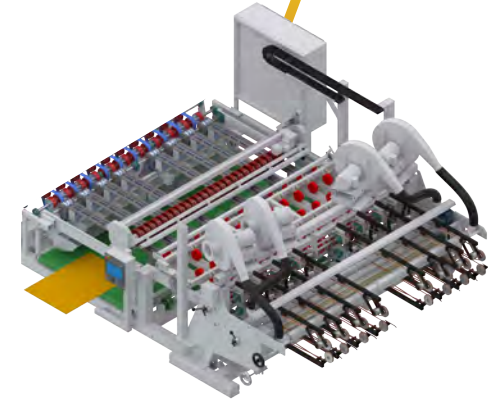

## eZF™ Load Former

- No Pits!
- Auto Cycle Modes
- Order Recipe Recall System
- Fast Cycle & Set Up Times
- Modular Design
- Integrated Safety Features
- Fully Electric

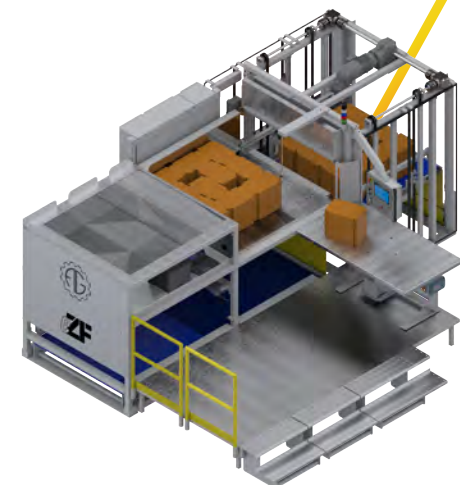

## Infeed™ Conveyor System

- Fully Powered Meshtop to Load
- Auto-Lift, Indexing and Queue Modes
- High Speed Down Mode to Decrease Cycle Time
- Accessible Forktruck Station

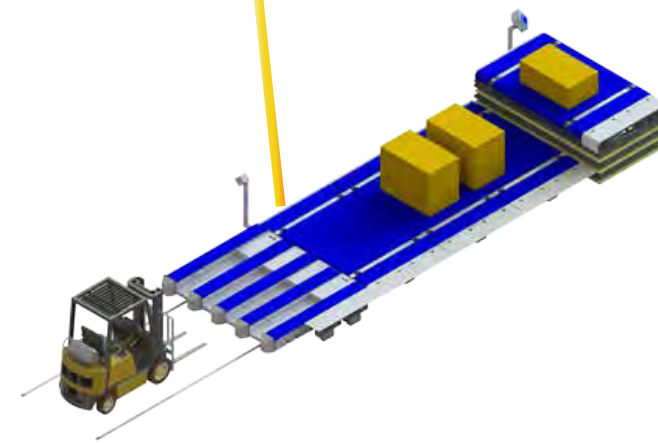

## DIGITALLY EMPOWERED SERVICE & SUPPORT



### SIMCORRA™ CUSTOM FACTORY SIMULATION

Step into a fully custom virtual factory with SIMCORRA™, a digitally-empowered factory planning tool tailored to the corrugated industry.



The GO AG™ Digital App empowers your team with customizable collaboration, training, maintenance, and productivity tools available through any digitally-connected device.



Boxmakers with A.G. MAX machine service contracts have access to advanced digital solutions, in-house machining capabilities, and a domestic partner for MAXimum productivity and profitability, all year long.

CONTACT THE A.G. TEAM TO DISCUSS YOUR PRODUCTION NEEDS!

